



**FALCON 8**  
AERIAL IMAGING SOLUTION





## TOPCON SOLUTIONS

The global construction, geospatial, and agricultural industries are rapidly changing thanks to quantum leaps in communication and measuring technologies that literally transform our perspectives of time and space. These advancements are reshaping the way things are designed, built, grown, and managed.

Topcon works to stay a step ahead of customers' needs by creating solutions that embrace and extend these advancements into the way they work – everywhere they work. Our high-accuracy positioning, high-speed imaging, enhanced field safety, and down-to-earth simplicity creates higher productivity and better results with lower environmental impact.

**YOUR PRODUCTIVITY.  
TECHNOLOGY.**

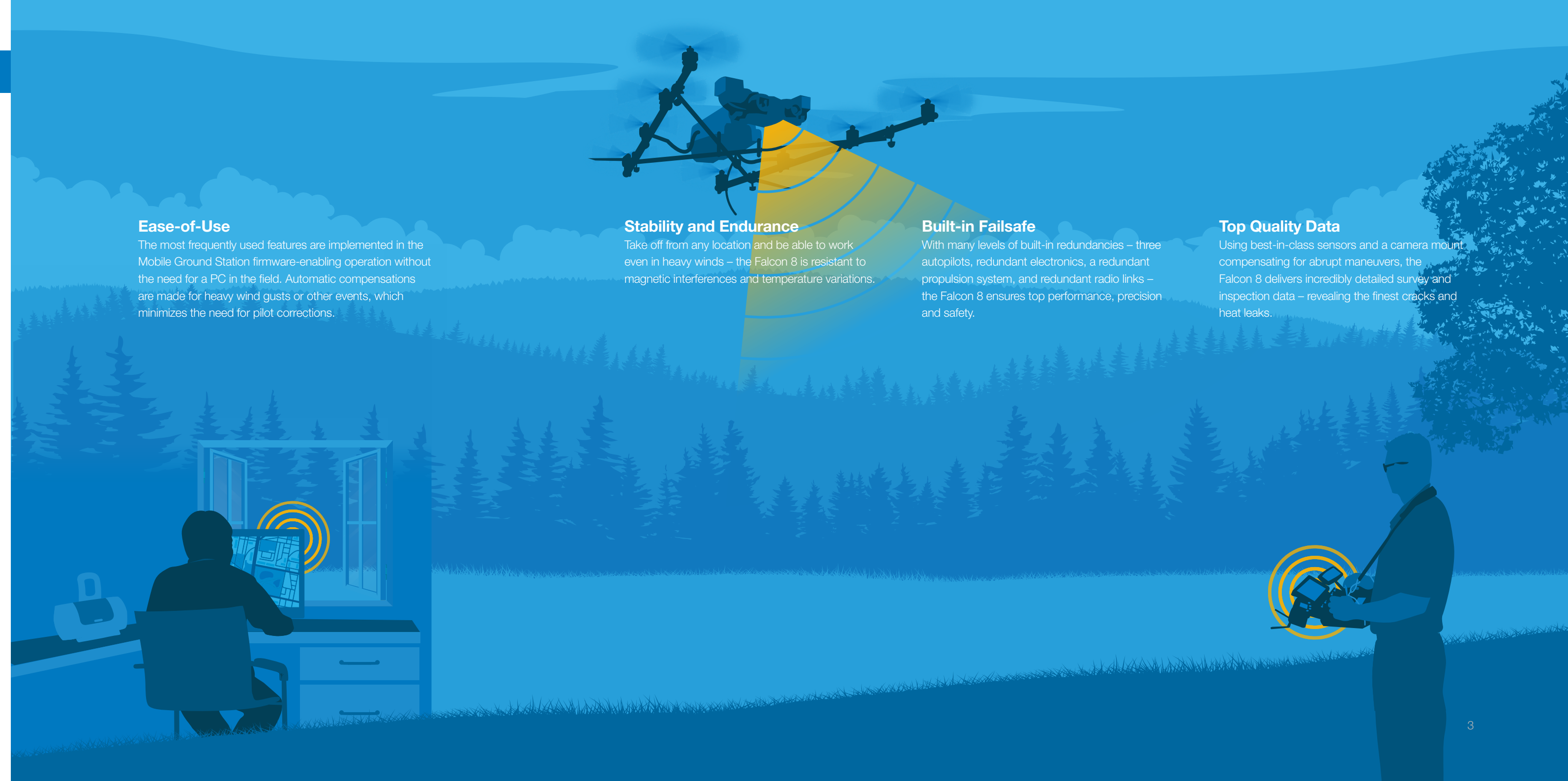

### Ease-of-Use

The most frequently used features are implemented in the Mobile Ground Station firmware-enabling operation without the need for a PC in the field. Automatic compensations are made for heavy wind gusts or other events, which minimizes the need for pilot corrections.

### Stability and Endurance

Take off from any location and be able to work even in heavy winds – the Falcon 8 is resistant to magnetic interferences and temperature variations.

### Built-in Failsafe

With many levels of built-in redundancies – three autopilots, redundant electronics, a redundant propulsion system, and redundant radio links – the Falcon 8 ensures top performance, precision and safety.

### Top Quality Data

Using best-in-class sensors and a camera mount compensating for abrupt maneuvers, the Falcon 8 delivers incredibly detailed survey and inspection data – revealing the finest cracks and heat leaks.





## Falcon 8

The Topcon Falcon 8 powered by Ascending Technologies is a rotary-wing UAS designed for inspection and monitoring or survey and mapping applications, depending on which camera payloads are used. Rotary-wing UASs are best applied to smaller scale projects and those for which flexibility for take-off and landing or oblique perspective is required. The Falcon 8 offers the flexibility to get into small spaces and compromising situations often presented in inspection and monitoring applications. Due to its best-in-class sensors, active vibration damping and actively compensating camera mount, the Falcon 8 is well suited for smaller mapping and inspection projects up to 35 hectares that require high resolution imaging.

There are two Falcon 8 models to choose from depending on your application:

- **GeoEXPERT** – Payload includes a high-resolution RGB camera (Sony Alpha 7R) for small survey, modelling and mapping projects.
- **InspectionPRO** – Payload consists of an RGB camera and IR sensor (Panasonic Lumix DMC-TZ71 + FLIR TAU 640) or the video camcorder (Sony HDR-PJ810E) for inspection and monitoring applications.

With the AscTec® Trinity, the UAS propulsion and complete flight control electronics are triple protected.







## Falcon 8 GeoEXPERT

- Efficient dam and wall survey
- Monument monitoring
- Geodata capture and analysis
- Vegetation control
- Mining surveys
- Archeology and geology
- 3D terrain modeling
- Inventory analysis
- Building surveys
- Volume surveys
- Construction progress and mapping

## Falcon 8 InspectionPRO

- Bridge and inspection survey
- Onshore and offshore inspections
- Windpark inspection
- Visual inspection of structural integrity
- Industrial indoor/outdoor inspection
- Solar park inspection
- Structural condition assessment operations



## SURVEY AND MAPPING

The Falcon 8 GeoEXPERT is a great solution for small mapping or survey projects with limited space for take-off and landing – which is often the case for projects in built-up areas or smaller construction sites. High-resolution geo-referenced aerial images can be taken from various heights, uniformly and precisely, within set GPS tolerances and offer a complement to conventional survey methods. The Falcon 8 can map 35 hectares in a single flight providing reliable material to create orthophotos or 3D models in Agisoft PhotoScan, or similar processing software.

The Falcon 8 can be used for:

- Archeology and geology
- 3D terrain modeling
- Inventory analysis
- Construction site mapping
- Volumetric 3D measurements
- Georeferenced 2D and 3D information
- Building survey and modeling







## INSPECTION AND MONITORING

Safety is required at many inspection sites where the environment can be dangerous and impacted. Falcon 8 offers the ultimate in safety. Remotely controlling the UAS with the Mobile Ground Station (MGS) keeps the pilot away from the site. Critical situations like strong wind and data link will clearly be indicated on the MGS with visual and acoustic warnings.

The Falcon 8 can fly anywhere and operate in the toughest weather conditions. As a result, important decisions can be made immediately saving time and resources.

The Falcon 8 offers:

- Less risk and expense than conventional methods
- Minimized downtime and safer shutdowns
- More quality and detail with HD imaging, thermal and RGB stills and videos
- Precise structure analysis and quick damage detection
- Low noise and emissions
- Robust functionality in electromagnetic fields
- Wind load balancing up to 15 m/s
- Second operator independent camera control

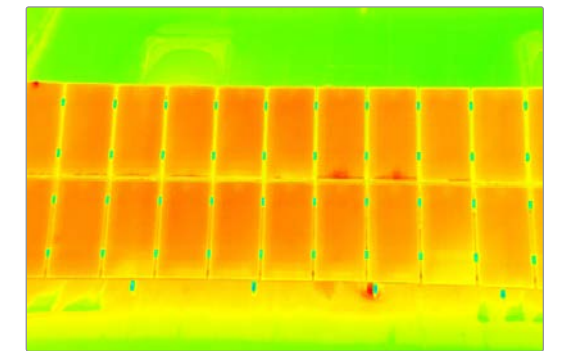





## PAYLOAD OPTIONS

The Falcon 8 is a lightweight octocopter using a patented V-shape design granting the camera an unobstructed view not only to look down, but also up, allowing structures like bridges to be inspected or surveyed from below. The UAS frame is made of specially designed carbon fiber components.

Every camera is modified and integrated mechanically and electronically into the camera mount. The combination of design and material leads to many advantages such as being lightweight, stable, flexible, and easily maintained.



## SURVEY AND MAPPING

The survey and mapping model of the Falcon 8, the GeoEXPERT, includes the Sony Alpha 7R payload. It reproduces the finest details with minimal image noise even in poor lighting.

In combination with a 35mm full-frame sensor and a Bionz-X image processor, the Sony Alpha 7R with ZEISS lens (Sonnar T FE 35 mm F/2.8 ZA) currently is the best available on the market.



## INSPECTION AND MONITORING

The inspection and monitoring model of the Falcon 8, the InspectionPRO, includes the Panasonic Lumix TZ71 and the FLIR TAU 640 2. With remote controlled 30x optical zoom (24-720 mm), the Panasonic Lumix DMC TZ71 produces high-resolution images from a safe distance. The high-sensitivity CMOS sensor and the excellent display processing unit provide luminous photo quality.

The FLIR TAU 640 2 simultaneously captures images at 640 x 512 pixels, includes second generation Digital Detail Enhancement and makes flight times of over 20 minutes possible.

Even small thermal leaks or defects on solar power plants can be detected from long distances.



## VIDEOGRAPHY

Enjoy blur-free, smooth video clips with the Sony Camcorder HDR-PJ810E with full HD quality and 12x optical zoom- and not just under ideal conditions. The Exmor R™ CMOS sensor and its Balanced Optical SteadyShot™ provide excellent results with no need for laying plates, stringing wires or installing mobile cranes.

Automatically fly any path as a hovering Steadicam through preprogrammed settings. Simply define the location and the time and capture the scene in no time.

In video mode, a single pilot steers the flight system with the right control stick while controlling the camera with the left.







## MOBILE GROUND STATION

The Mobile Ground Station (MGS) is the main UI of the Falcon 8 UAS. Data links, remote control of the camera, video link, video display and the controls for the Falcon 8 are completely integrated into the MGS. Flight data, camera settings and live images are always at hand on your MGS and at the same time provide absolute freedom of movement.

The mobile ground station includes:

- Remote control
- Status display
- Dual diversity data link for telemetry in real time
- Analog video receiver
- HD video monitor

The optional independent camera control and video goggles allow two person operation for inspection flights.







## NAVIGATOR SURVEY SOFTWARE

The Falcon 8 comes with flight planning software as part of the survey package for ease-of-use. As part of the package, users receive:

- **AscTec® Navigator** – Waypoint flight planning software
- **Photo Tagger** – combine logs with images for use in post-processing software

The AscTec® Navigator is easy-to-use flight planning software for carrying out complex surveying projects with the minimum time and effort. With just a few clicks you can plot matrices, define routes and set all relevant system and camera parameters. Missions can be edited at all times and can be exactly reproduced as often as desired.

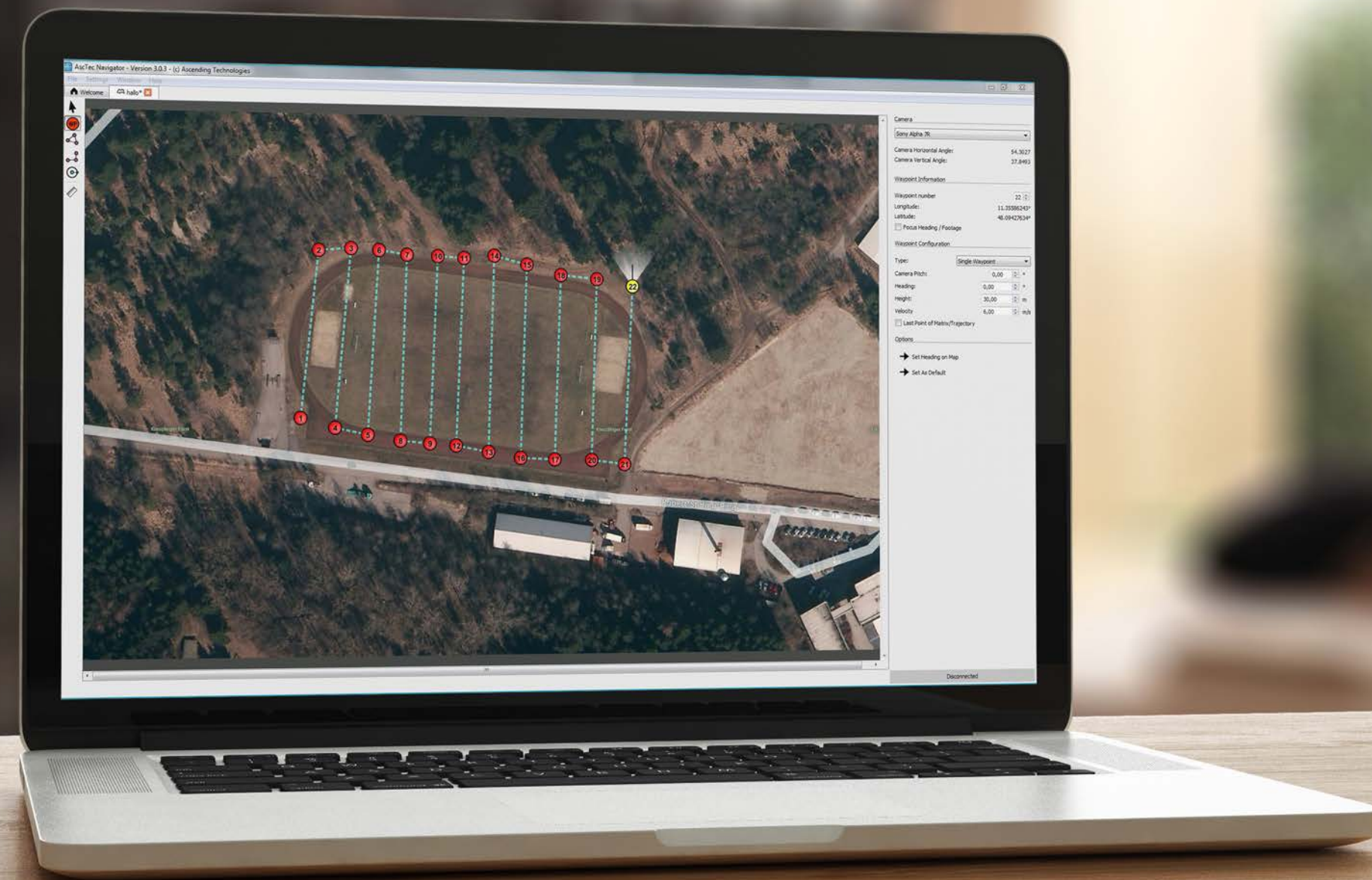





## KIT COMPONENTS

Falcon 8 GeoEXPERT for surveying and mapping includes:

- Falcon 8 – high-end octocopter
- Mobile Ground Station
- High-resolution digital camera, Sony Alpha 7R
- Software options: photo package or survey package
- Batteries
- Chargers
- LiPo safety bag
- Transport case
- Backpack

Falcon 8 InspectionPRO for inspection and monitoring includes:

- Falcon 8 – high-end octocopter
- Mobile Ground Station
- Inspection payload TZ71 (RGB+IR camera combination)
- Independent camera control
- Software options: photo package
- Video goggles
- Batteries
- Chargers
- LiPo safety bag
- Transport case
- Backpack



1 Central unit

2 Actively stabilized mount with camera

3 Carbon cross

4 Motor rails

5 Data link antennas

6 Video link antenna





## GeoEXPERT WORKFLOW

The Falcon 8 comes fully assembled and ready to fly. Pre-flight setup and planning steps are minimal, which offer a simple, streamlined workflow for new users. The maximum take off weight of the UAS is only 2.3 kg and the system is of high quality – made and tested in Germany.

- High-reliability, safety and performance
- Simple operation with high-tech autopilot
- Automated waypoint navigation
- Program and automate flight paths
- Backpack for off-road missions to remote locations



## FLIGHT PLANNING



Flight planning is simple, much is contained in the Mobile Ground Station firmware. Simply enter your required parameters to survey your area of interest right at the project site. Flight pattern and attitude are automatically optimized and defined by your settings.

Optionally, plan your flights with AscTec® Navigator desktop software to generate high-quality and easy-to-edit material in just a short period of time.

## IMAGE ACQUISITION



- Position yourself to overview the complete area you want to survey.
- Position the Falcon 8 in one of the corners of that area and align its heading with the first line of your flight pattern.
- Select the Quick Survey function via Status Display on the Mobile Ground Station and follow the assistant to set the required configuration.
- Define turning direction (left/right), inline and slide overlap (in %).
- Define the required ground sampling distance (GSD). Click "Start" and your Quick Survey begins.

## POST PROCESSING

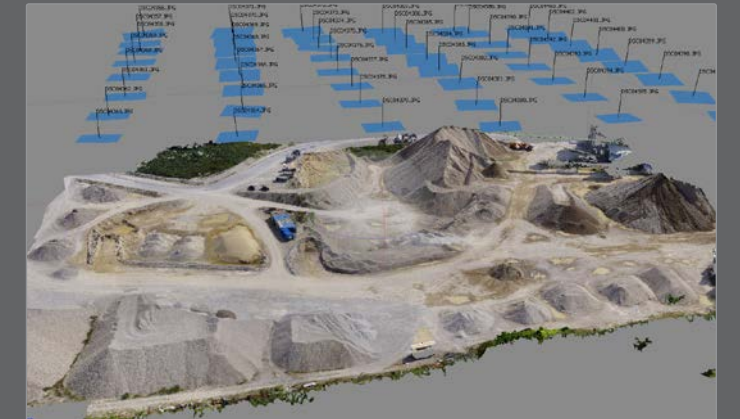

Transfer your data utilizing a simple USB interface.

Use Photo Tagger to post-process log files and to combine logs with images or utilize Agisoft Photoscan Pro for post-processing survey missions.





## InspectionPRO WORKFLOW

High-risk applications demand advanced workmanship and tools. The unique functions and advanced flight characteristics of the Falcon 8 InspectionPRO make it a superb tool for inspection and monitoring projects. Pre-flight setup and planning steps are minimal.

- Combination of thermal and digital camera
- Independent camera control for a second camera operator
- Video goggles for quick live view and initial diagnosis
- Magnetic resistance
- Automated 3D flights can be reproduced



## FLIGHT PLANNING



The Falcon 8 gives you full control over your flight planning. Manually fly the Falcon 8 around the object to be inspected, or program your flight path in advance. Save your accomplished flight path and repeat it automatically for exact comparison during a next inspection.

## FIELD REVIEW



View real-time data on the monitor of the Mobile Ground Station or using the video goggles. Freely adjust the Falcon 8's alignment and image zoom using the live image.

## IMMEDIATE DECISIONS



Important decisions can be made immediately or at the end of the flight on the basis of reliable pictures and video footage. Whether it is a hairline fracture or an energy leak – every second counts – the RGB and infrared images provide full insight.





## SAFETY AND SPECIFICATIONS

The Topcon Falcon 8 uses the groundbreaking AscTec® Trinity technology, making your Falcon 8 even more efficient and safe in daily operation. AscTec® Trinity is the first fully adaptive control unit (autopilot) with up to 3 levels of redundancy for multi-rotor flight systems. Three IMUs synchronize all sensing data and would identify, signal and compensate in case of trouble.

Further unique safety features include:

- **Redundant propulsion system:** Automatic compensation of defect propellers, motors or motor controllers.
- **Perfectly predictable flight behavior:** Even in weak GPS environment or magnetic fields.
- **Unbelievable position accuracy:** Tiny positional corrections are possible with extreme precision.
- **Minimal impact energy:** Super lightweight system with micro sized 8 inch propellers.

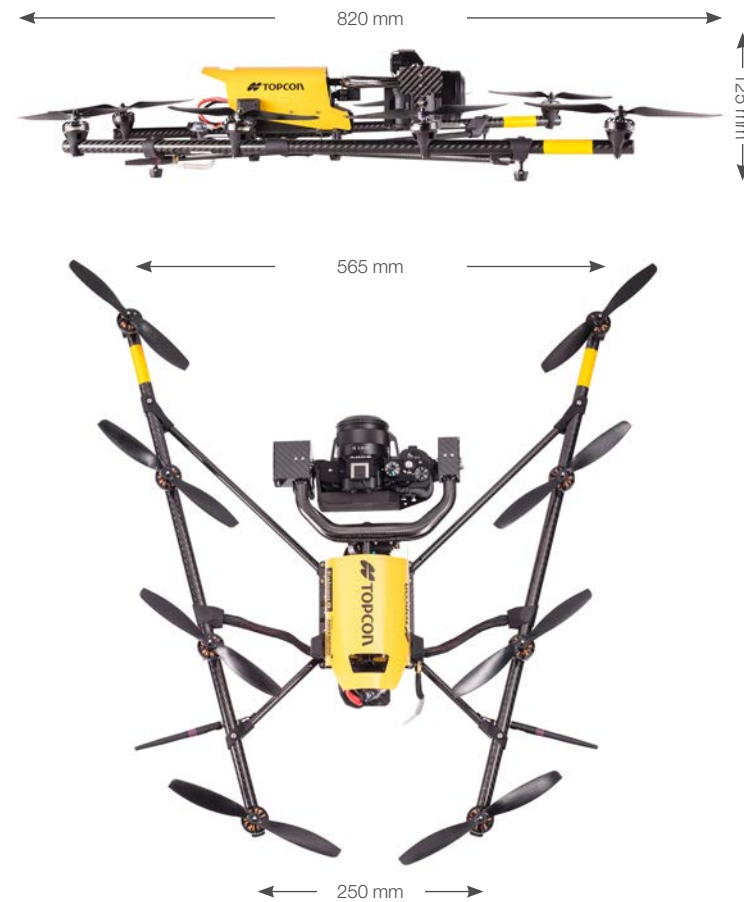

Flight Systems	
Type	V-Form Octocopter
Dimensions	770 x 820 x 125 mm
Engines	8 electric brush-less motors
Rotor Diameter	20 cm (8 inches)
Rotors	Total Rotors: 8 / Weight: 6 g each
Weight	Without payload: 1086 g Max Take-off: 2.3 kg Max Payload: 800 g
Flight Time	12 - 22 minutes
Maximum Flight Range	1 km
Tolerable Wind Speed	Up to 15 m/s
Navigation Sensors	
AscTec® Trinity (IMU, barometer and compass)	
AscTec high-performance GPS (GNSS)	
Maximum Airspeed	
Manual Mode	15 m/s
Height Mode	15 m/s
GPS Mode	4.5 m/s
Maximum Climb / Sink Rate	
Manual Mode	6 - 10 m/s
Height Mode	3 m/s
GPS Mode	3 m/s

Wireless Communication
2x Independent (diversity) control/data links
2.4 GHz FHSS link (10' to 63 mW)
1 Analogue diversity video receiver
5.8 GHz (25 mW)
LiPo Battery Types (mAh)
PP 6250 / 3 Cells 6250 (~ 426 g)
Available Payload Options
Sony Alpha 7R
Panasonic Lumix TZ71 + FLIR TAU 640
Sony Camcorder HDR-PJ810E
Certifications
CE
RoHS





## WITH YOU ALL THE WAY

Our mission is simple - to help grow your business. Sure, that helps us grow ours, and together we can help ensure that a growing world is a healthy world. That's the Topcon vision and why more than 2,000 employees worldwide are dedicated to creating the technologies and bringing you the solutions to drive your success.

From our scientists in our state-of-the-art research labs to our solutions developers dedicated to understanding the challenges you face, we're focused on helping your business grow in efficiency and strength.

The world has a long to-do list. With 9 billion people expected on the planet by 2030, there's a lot of work to be done. We'll need more housing, roads and utilities. Topcon is driven to help you meet these demands with innovative solutions that help you work smarter and faster to create sustainable infrastructure. The innovative solutions and committed support from Topcon are all you need to build the future with confidence.

### TotalCare

Topcon TotalCare is dedicated to helping you solve your workflow challenges, and get the most out of your Topcon solutions.

Get expert training from our large collection of online materials. Access software and firmware updates, current publications, tech tips, and guidance from the experts all from your computer or mobile device.

[topconpositioning.com/support](https://topconpositioning.com/support)







[www.topconpositioning.com](http://www.topconpositioning.com)

